

Commercial Microwave with push buttons & stainless steel cavity



120V 1000W



Features

- 10 programmable memories, including defrost, save time and simplify cooking
- 4 power settings provide a variety of cooking options
- Timer counts to 99:99 (min/sec)
- Interior oven light
- Durable stainless steel interior and exterior provide a sleek appearance
- 4 legs provide a 1 $\frac{3}{4}$ " clearance from the countertop
- See-through door and lighted interior allows the user to monitor cooking
- 6 month replacement warranty

Dimensions

Capacity	.9 cu. ft.
Unit Dimensions	20"W x 12"H x 18.5"D
Oven Cavity Dimensions	13"W x 8"H x 13.25"D
Shipping Weight	39 lbs.
Product Weight	34 lbs.

Electrical

Voltage	120V
Hz	60 Hz
Phase	Single
Wattage	1000W
Usage Level	Light Duty

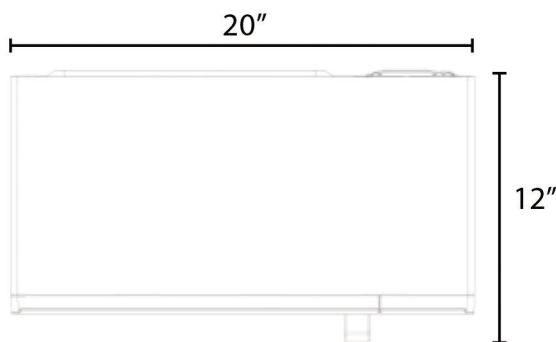

BACK

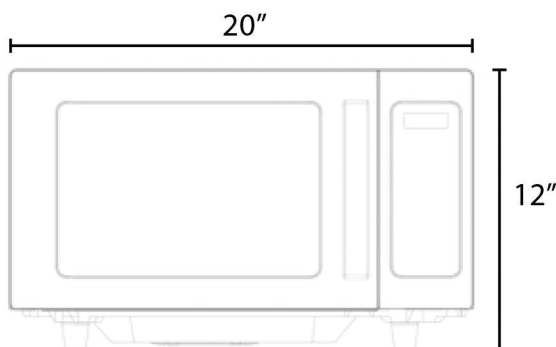

FRONT

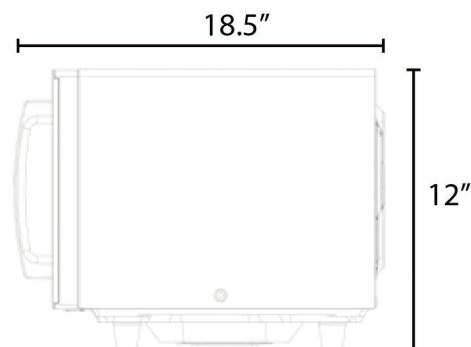

SIDE

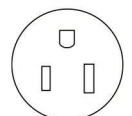

NEMA 5-15P